

**Instruction Manual  
Vari-Notch Duplexers (6" Cavities)**

Copyright © 1997 TX RX Systems, Inc.

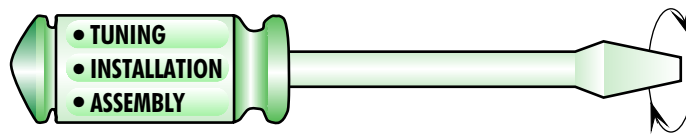

8625 Industrial Parkway Angola, NY 14006-9696 (716) 549-4700 24-hr Fax (716) 549-4772  
*A Member of Bird Technologies Group*



Part No.  
7-9177-1

## Instruction Manual Vari-Notch Duplexers (6" Cavities)

Copyright © 1997 TX RX Systems, Inc.

First Printing : September 1997

Version Number	Version Date
1	09/19/97

## **WARRANTY**

***This warranty applies for one year from shipping date.***

TX RX SYSTEMS INC. warrants its products to be free from defects in material and workmanship at the time of shipment. Our obligation under warranty is limited to replacement or repair at our option, of any such products (with the exception of tubes) which shall have been defective at the time of manufacture. TX RX SYSTEMS INC. reserves the right to replace with merchandise of equal performance although not identical in every way to that originally sold. TX RX SYSTEMS INC. is not liable for damage caused by lightning or other natural disasters. No product will be accepted for repair or replacement without our prior written approval.

All Shipping charges on returned products must be prepaid by the purchaser. TX RX SYSTEMS INC. shall in no event be liable for consequential damages, installation costs or expenses of any nature resulting from the purchase or use of products, whether or not they are used in accordance with instructions. This warranty is in lieu of all other warranties, either expressed or implied, including any implied warranty of merchantability or of fitness. No representative is authorized to assume for TX RX SYSTEMS INC. any other liability or warranty than set forth above in connection with our products or services.

## GENERAL DESCRIPTION

Vari-Notch® duplexers are used to provide simultaneous operation of a transmitter and receiver (or two transmitters) which are operating at different frequencies while connected to a common antenna. These duplexers are frequently used in radio repeater systems. This instruction manual (part# 7-9177-1) covers the installation, tuning, and maintenance of Vari-Notch duplexers constructed from 6.625" diameter cavities. Table 1 shows the model numbers and electrical specifications of the duplexers covered by this manual.

Vari-Notch duplexers are composed of two groups (or sets) of daisy-chained resonant cavity filters, which couple signals to and from the shared antenna. This creates two signal paths, a high frequency channel and a low frequency channel. The minimum frequency separation between the channels, as well as the isolation in dB's (per channel and between channels) is listed for each model in table 1.

The cavity filters used in a transmit channel will reduce transmitter noise components at the receive frequency, thus preventing noise desensitization of the receiver. Conversely, the cavity filters used in a receive channel will isolate the receiver from the transmitter carrier preventing carrier desensitization of the receiver.

Resonant cavity filters are the basic building blocks of the system. Also important, are the interconnect cables between each filter which have cut length's equivalent to either  $1/4\lambda$  or  $3/4\lambda$  of that channels pass frequency. The exception is the antenna cable that couples each channels final filter to the antenna port, which is cut to  $1/2\lambda$  of the other (or remaining) channels pass frequency. This effectively places a relatively large impedance in parallel with the antenna, insuring a good impedance match between the other (or remaining) channel and the antenna. This technique of impedance matching allows both channels to be connected to the same antenna with very little loss due to mismatching. The antenna cables are permanently soldered and crimped to the antenna junction. The combination of the antenna junction and the attached antenna cables is referred to as an "Antenna Junction Assembly".

Figure 1 on page 2 shows the functional block diagram of a typical four-cavity Vari-Notch duplexer system. Six and eight cavity systems are similar except for the extra filters in each channel. The photograph shown in figure 2 on page 3 is the front view of a typical four-cavity Vari-Notch duplexer. Each of the physical components in the system is labeled with the field adjustable parts shown in emboldened italics.

Model Number	Frequency Range (MHz)	Power Rating (Watts)	Min. Freq. Separation (MHz)	Insertion Loss (dB)	Isolation (dB)	
					Per Chan.	Bet Chan.
28-13-01F	30-40	400	0.3	1.5	90	50
28-14-01F	38-50	400	0.3	1.5	90	50
28-28-02A/G	66-88	400	0.35	1.5	85	50
28-36-02A/G	132-150	400	0.5	1.5	85	50
28-36-11E/G	132-150	400	0.3	2.2	100	50
28-37-02A/G	144-174	400	0.5	1.5	85	50
28-37-11E/G	144-174	400	0.3	2.2	100	50
28-37-08G	144-174	400	0.24	3	100	50
28-65-01A	406-430	350	1.5	1.5	90	50
28-65-05A/G	406-430	350	0.7	2.2	100	50
28-70-01A	450-470	350	1.5	1.5	90	50
28-70-07A/G	450-470	350	0.7	2.2	100	50
28-69-01A	470-512	350	1.5	1.5	90	50
28-69-04A	470-512	350	0.7	2.2	100	50

Table 1: Vari-Notch Duplexer electrical specifications (for 6.625" diameter cavities).

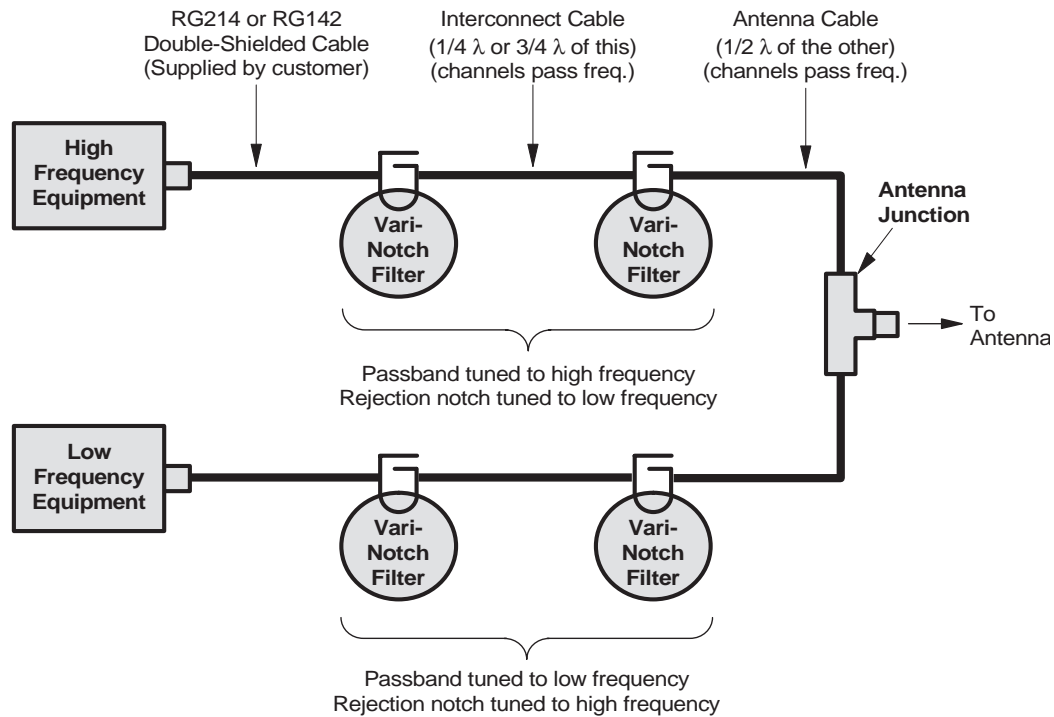

### TYPICAL FOUR CAVITY VARI-NOTCH FILTER

Figure 1: Block diagram of a typical four-cavity Vari-Notch Duplexer (6.625" diameter cavities).

#### UNPACKING

Care should be used when removing the duplexer from its shipping container to avoid unnecessary damage. It is important to visually inspect the duplexer for any shipping damages as soon as possible after taking delivery. *It is the customers responsibility to file any necessary damage claims with the carrier.*

Vari-Notch duplexers are rugged devices but may become detuned if jostled or dented during shipping. The most easily damaged parts of the duplexer are the tuning rods. These rods are marked where they exit from the locking nut with a dab of red varnish or other color/type of paint. If this seal appears to be broken it may indicate that the system has been detuned in transit.

#### INSTALLATION

Vari-Notch duplexers should be securely installed in a dry, vibration-free environment. Attachment of the cavity shells to a grounding bus is recommended in order to maximize lightning protection. A lightning protection device placed in the antenna feedline, preceding the duplexer, is also recommended. High quality double shielded coaxial cable terminated with quality connectors (N-type) are recommended for connecting the transmitter and receiver to the duplexer, and are available from TX RX Systems Inc. It is also important to observe

the power handling ratings of cables in transmit systems.

Mount the duplexer in its permanent operating position using suitable hardware. Connect the two transmitters (or transmitter/receiver) and the antenna feedline to the duplexer making sure to connect the correct equipment to the correct port. Labels are affixed next to each port (port labels) to help you make the right connections. In addition, a specification tag will be found in a plastic bag attached to one of the tuning rods. The frequency that each cavity group is tuned to will appear on either the port labels or the specification tag. The duplexer is now ready for normal operation. No tuning is required if the frequencies (high frequency and low frequency) found on the port labels/specification tag matches the actual operating frequencies.

#### MAINTENANCE

No special maintenance is required. Vari-Notch duplexers are passive devices of rugged electrical and mechanical design. They are tuned at the factory for the original design requirements and require no further adjustment or maintenance. These devices will stay properly tuned unless they have been physically damaged or are tampered with. Check for loose or corroded connectors on

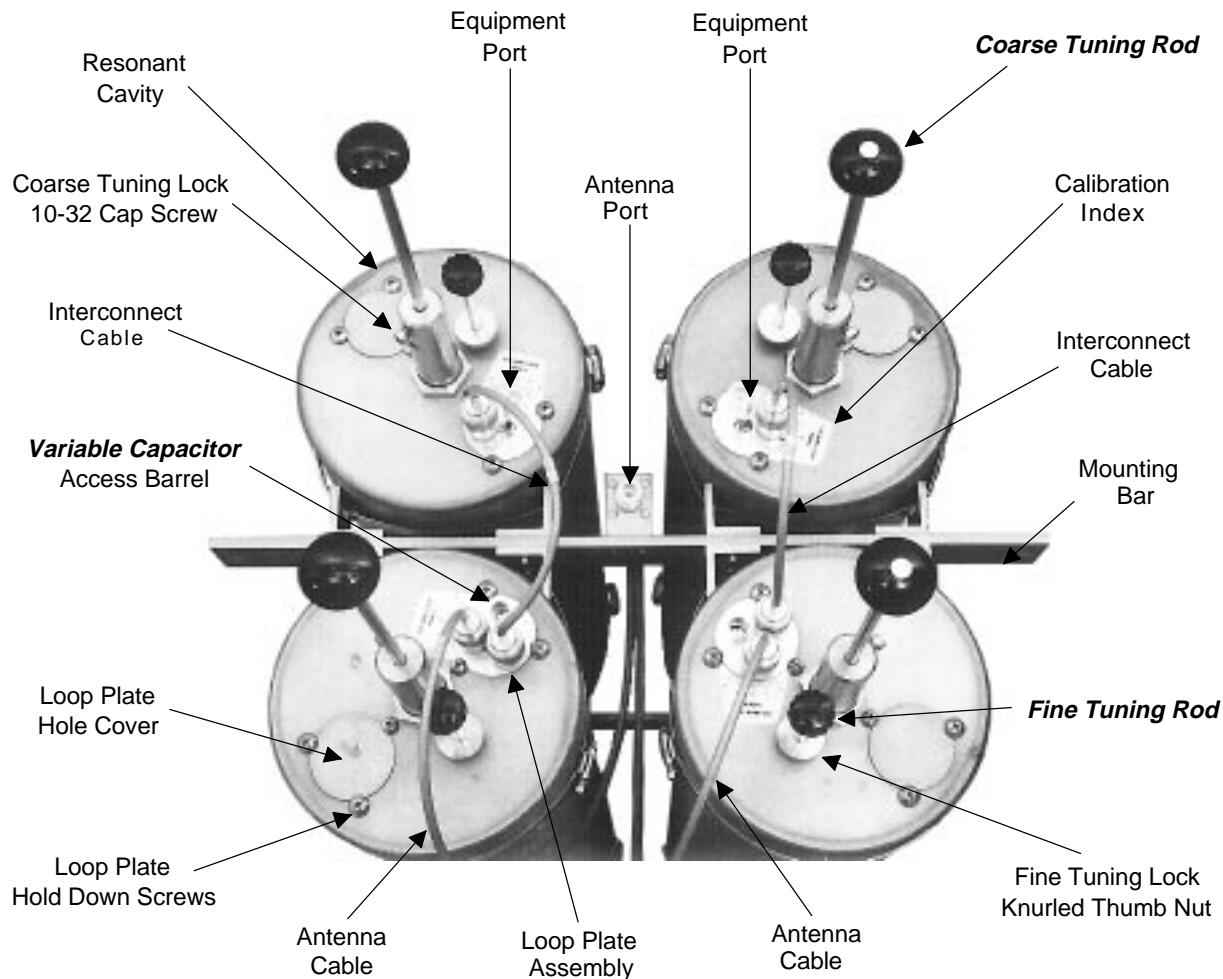

Figure 2: Top view of a typical four-cavity Vari-Notch Duplexer (6.625" diameter cavities).

the interconnect cables whenever an inspection is performed on other station equipment.

Because duplexers are passive devices, field repairs are rarely required. Field repair of duplexers is limited to the replacement or repair of damaged cables. Cavity damage, when it occurs, is usually due to catastrophic failure from lightning or power far in excess of the duplexers rating. If cavity problems are suspected, the unit should be returned to the factory for repair. Due to the critical alignment of parts inside of the cavity resonators, field repair is not recommended.

### TUNING

Vari-Notch duplexers are originally pre-tuned at the factory to the customers specification. To re-tune the duplexer, each resonant cavity must be separated from the group and adjusted individually. Then the individual cavities are re-connected and each channel is fine tuned to peak it's overall response. When reconnecting the assembly, it is

mandatory that each filter and cable be replaced in it's original position.

There are two adjustable parameters found in a Vari-Notch filter; the *pass frequency* and the *rejection notch*. Adjustment of the coarse and fine tuning rods will allow the filters passband to be centered at the desired frequency. The rejection notch frequency is adjusted by turning the variable capacitor located on the loop plate assembly.

The insertion loss of a cavity is determined by the position of the loop plate and is not field adjustable. **The loop plate on a 6.625" cavity should never be loosened or moved** from it's factory preset position.

It is also important to note that the insertion loss specification in table 1 for each of the different models, is the total insertion loss for each channel of that model. For instance, the specification for model 28-13-01F is 1.5 dB, this means both the high and low frequency channels will each have a

total of 1.5 dB of insertion loss. The total insertion loss is the sum of losses from each cavity in the channel as well as from the interconnecting cables between the cavities.

### Required Equipment

Due to the sensitivity of the adjustments, it is strongly recommended that the proper equipment be used when tuning the individual filters, otherwise the filter should be sent to the factory or an authorized representative for retuning. The following equipment or it's equivalent is recommended in order to properly perform the tuning adjustments for the Vari-Notch duplexer.

1. IFR A-7550 spectrum analyzer with optional tracking generator installed.
2. 5/32" hex wrench.
3. Double shielded coaxial cable test leads (RG142 B/U or RG223/U).
4. 50 ohm load with at least -35 dB return loss (1.10:1 VSWR). The JFW Industries model 50T-007 or equivalent.
5. Female union (UG29-N or UG914-BNC).
6. Return Loss Bridge (Eagle model# RLB150N3A).
7. Insulated tuning tool (TX RX Systems Inc. part# 95-00-01).

### Tuning Procedure

Tuning of the filter requires adjustment of the *passband* and the *rejection notch*. The passband is adjusted while observing the return loss response and the rejection notch is adjusted by monitoring the output of a tracking generator after it passes through the filter.

All Vari-Notch filters should be temporarily removed from the system and tuned on the bench using test instrumentation only. Do not adjust the filters while they are under transmit power. To insure proper tuning of the 6.625" Vari-Notch filter, all adjustments should be performed in the following order:

1. Rough tune the passband.
2. Rough tune the rejection notch.

3. Final tune the passband.
4. Final tune the rejection notch, always the last adjustment made.



**WARNING - Tuning while under transmit power can result in damage to the duplexer.**

### PASSBAND

The peak of the passband will correspond very closely to the point of minimum reflected energy from the filter and maximum forward power through it. A transmitter connected to the filter will operate best when the reflected energy is lowest, therefore the return loss response will be used to set the passband. The passband can be checked and adjusted using the following procedure.

### Checking the passband

1. A zero reference for return loss must be established at the IFR A-7550 prior to checking the passband frequency, this is done by connecting the return loss bridge to the analyzer / generator as shown in figure 3.

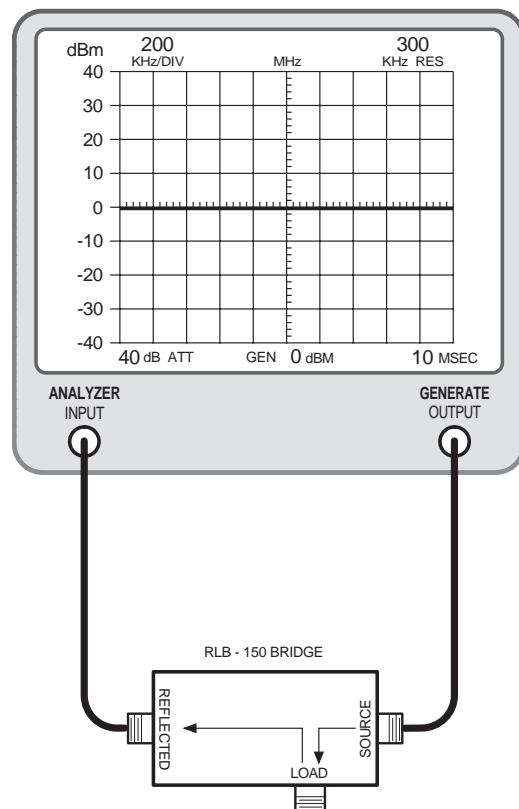

Figure 3: Setting the return loss reference.

2. Set-up the analyzer / generator for the desired frequency (center of display) and for a vertical scale of 10 dB/div.
3. Do not connect the return loss bridge (RLB) to the cavity, leave the "load" port on the bridge open. This will supply the maximum amount of reflected energy to the analyzer input.
4. Insure that the IFR A-7550 menu's are set as follows:
  - DISPLAY - line
  - MODE - live
  - FILTER - none
  - SETUP - 50 ohm/dBm/gen1.
5. The flat line across the screen is the return loss curve. Select the "MODE" main menu item and then choose the "STORE " command.
6. Next select the "DISPLAY" main menu item and choose the "REFERENCE" command. This will cause the stored value to be displayed at the center of the screen as the 0 dB reference value.
7. Connect the "load" port on the RLB to the input of the loop plate, make sure the output of the loop plate is connected to a 50 ohm load, refer to figure 4. The display will now present the return loss curve for the 6.625" Vari-Notch filter being measured. **The passband is that frequency range over which the return loss is 15 dB or greater.**

### Adjusting the passband

Set the fine tuning rod at it's mid-point. Adjust the passband by setting the peak (maximum negative value) of the return loss curve at the desired passband frequency (should be the center-vertical graticule line on the IFR A-7550's display). Refer to figure 4.

The resonant frequency is adjusted by using the coarse tuning rod, which is a sliding adjustment (invar rod) that rapidly tunes the response curve across the frequency range of the filter. Resonant frequency is increased by pulling the rod out of the cavity and is decreased by pushing the rod into the cavity. Additionally, the fine tuning rod, also a sliding adjustment (silver-plated-brass rod) allows a more precise setting of the frequency after the course adjustment is made. The frequency is increased by pushing the fine tuning rod in and is

decreased by pulling it out; the exact opposite of the coarse tuning rod. For ease in making adjustments, rotate and slide the rods while gently tapping on them with a screwdriver handle or other small tool. This will break the surface tension on the probe contact fingers and allow smoother movement of the tuning rods.

### Cavity Tuning Tip

When tuning a cavity that has been in service for some time it is not unusual to find the main tuning rod hard to move in or out. This occurs because TX RX Systems Inc. uses construction techniques borrowed from microwave technology that provide

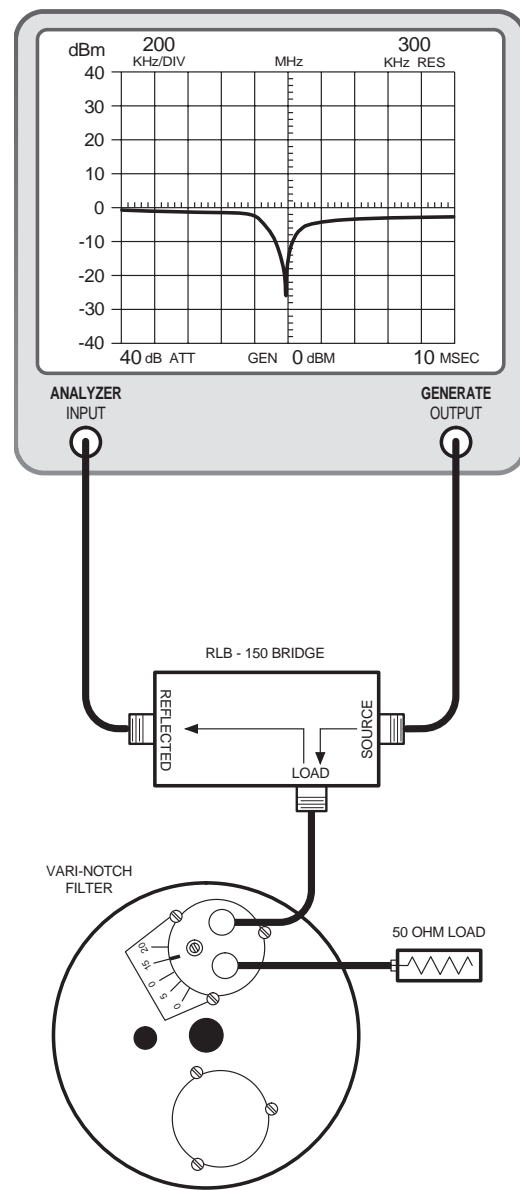

Figure 4: Checking the passband.



large area contact surfaces on our tuning probes. These silver plated surfaces will actually form pressure welds which maintain excellent conductivity. The pressure weld develops over time and must be broken in order for the tuning rod to move. This is easily accomplished by gently tapping the tuning rod with a plastic screwdriver handle or small hammer so it moves into the cavity. The pressure weld will be broken with no damage to the cavity.

Once the desired response is obtained using the coarse and fine tuning rods, they are "locked" into place. The coarse rod is secured by tightening the 10-32 cap screw and the fine tuning rod is held in place by tightening the knurled thumb nut. **Failure to lock the tuning rods** will cause a loss of temperature compensation and detuning of the cavity.

### REJECTION NOTCH

The rejection notch will track with the tuning of the passband and therefore should be the last adjustment made to the 6.625" Vari-Notch filter. The rejection notch is adjusted by changing the amount of capacitance in the loop assembly. The capacitor is variable and is either an air-plate or tubular piston type depending upon the frequency range of the filter. The air-plate type has a red mark painted on the access barrel and one-half of the adjusting screw, when the red marks line up the maximum capacitance is achieved. On UHF models (400 MHz and over) the capacitor access barrel is omitted and a 10-32 inch screw must then be removed from the loop plate assembly to gain access to the piston trimmer under the plate.

#### Checking the rejection notch

1. The rejection notch is checked by connecting the tracking generator to the input of the cavity filter while the spectrum analyzer is connected to the output, as illustrated in figure 5.
2. Insure that the IFR A-7550 menu's are set as follows:
  - DISPLAY - line
  - MODE - live
  - FILTER - none
  - SETUP - 50 ohm/dBm/gen1.

#### Adjusting the rejection notch

The notch is adjusted by turning the variable capacitor. Because of the filters sensitivity to tool contact, an insulated tuning tool must be used to make the adjustment.

### FINE TUNING THE CHANNELS

Once all of the individual filters have been tuned, each of the channels as a whole must be fine tuned. First the passband for both channels and then the rejection notches. The following is a step by step procedure for fine tuning the channels and completes the re-tuning of the duplexer.

1. Reassemble the duplexer by reinstalling the cavities and interconnect cables in their original locations.
2. The *passband* for the channels are fine tuned first, in a manner very similar to tuning a single cavity.
3. A zero reference for return loss must be established at the IFR-7550. Connect the RLB to the analyzer / generator as shown in figure 3.

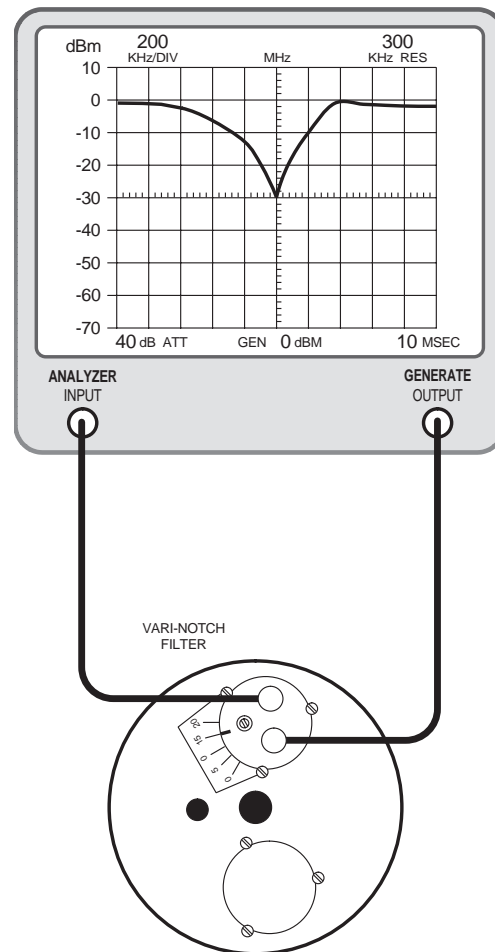

Figure 5: Checking the rejection notch.

4. Set-up the analyzer / generator to the desired frequency (center of display) and for a vertical scale of 10 dB/div.
5. Do not connect the RLB to the duplexer at this time, leave the "load" port on the bridge open. This will supply the maximum amount of reflected energy to the analyzer input.
6. Insure that the IFR A-7550 menu's are set as follows:
  - DISPLAY - line
  - MODE - live
  - FILTER - none
  - SETUP - 50 ohm/dBm/gen1.
7. The flat line across the screen is the return loss curve. Select the "MODE" main menu item and then choose the "STORE " command.
8. Next select the "DISPLAY" main menu item and choose the "REFERENCE" command. This will cause the stored value to be displayed at the center of the screen as the 0 dB reference value.
9. Connect the "load" port on the RLB to the equipment port of the channel to be fine tuned. Terminate the duplexers antenna connector with the 50 ohm load. The equipment port of the remaining duplexer channel is left disconnected, refer to figure 6.
10. The display will now present the combined return loss curve for all of the cavities in the channel. The channels passband is that frequency range over which the return loss is 15 dB or greater.
11. Fine tune the passband for the entire channel (for maximum return loss) by gently adjusting the positions of the fine tuning rods (coarse rods if needed) moving between cavities as required. Once the desired response is obtained "lock" the tuning rods into place by tightening the 1/4" shaft lock nuts and the knurled thumb nuts on each filter.
12. Move the cable from the RLB's "load" port to the equipment port of the other channel. This will allow the remaining duplexer channel to be fine tuned. Reset the analyzer / generator center frequency. Repeat steps 10 and 11.
13. The *rejection notch* for each of the channels must be fine tuned next.

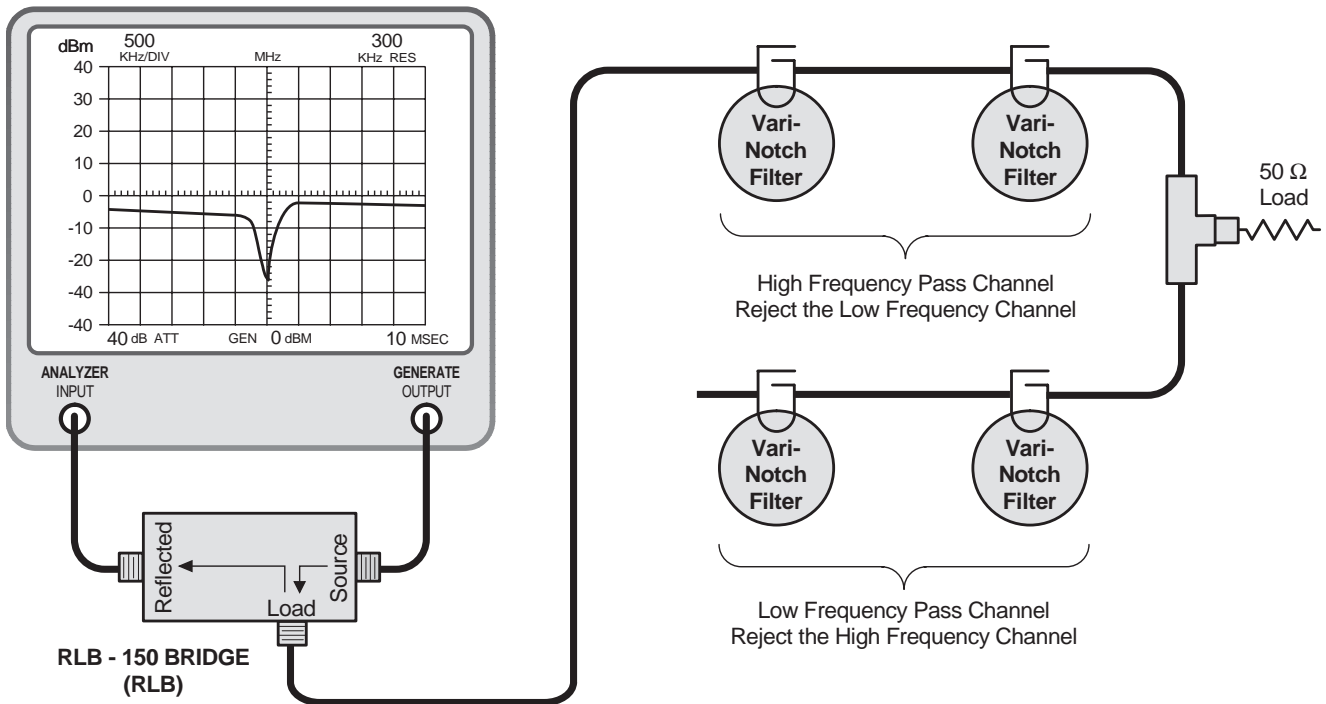

Figure 6: Equipment setup for fine tuning the passband of each channel.

14. Terminate the antenna connector with a 50 ohm load. Connect the output of the tracking generator to the equipment port of one of the duplexer channels and the spectrum analyzer input to the equipment port of the remaining channel as shown in figure 7.

15. Set-up the analyzer / generator to sweep across the rejection notch frequency of the channel being tuned. The center of the display should be set to the desired center frequency of the rejection notch being adjusted. Set the vertical scale of the analyzer / generator to 10 dB/div.

Keep in mind that the high frequency channel has its rejection notch set to reject the low frequency signal and vice-versa for the rejection notch of the low frequency channel.

16. Insure that the IFR A-7550 menu's are set as follows:  
 DISPLAY - line  
 MODE - live  
 FILTER - none  
 SETUP - 50 ohm/dBm/gen1

17. Set the analyzers attenuation control so that the 0 dBm level is at the top of the display.

The display will now show most of the rejection notch. Using the analyzer's attenuation control adjust the amount of attenuation so that the "peak" or lowest value on the rejection notch is displayed.

18. The cavities rejection notches are adjusted (for maximum rejection) by gently turning the variable capacitors in the loop plate assemblies. Move between filters as needed.

Because of the filters sensitivity to tool contact, an insulated tuning tool must be used to make the adjustment..

19. Adjust the rejection notch of the remaining cavities by changing the sweep frequency of the analyzer / generator to match the new rejection notch frequency. The equipment stays connected as it is.

20. Repeat step 17 and 18 for the remaining channel (cables and equipment stay connected where they are).

21. With the tuning completed, reconnect the equipment cables and antenna feedline. Test the system for proper operation.

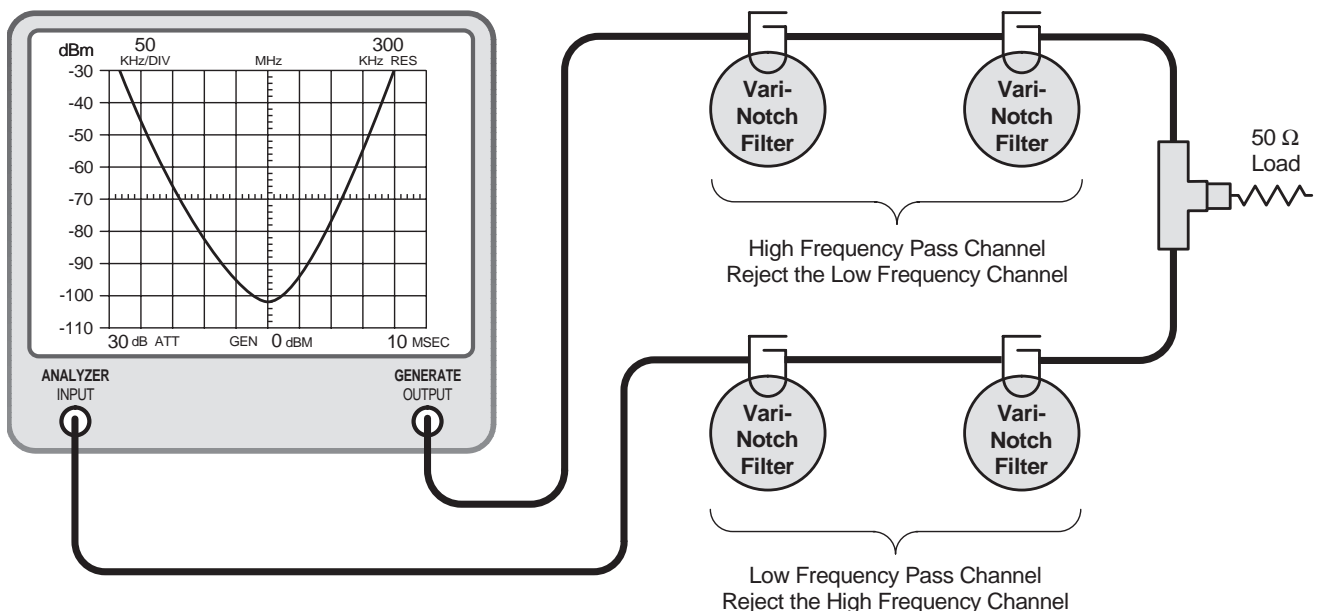

Figure 7: Equipment setup for fine tuning the rejection notch of each channel.

# DUPLEXER PROBLEMS AND REMEDIES

Duplexers are passive devices requiring little or no service once installed in a system. The proper design and application of a given Duplexer will give years of trouble free service. When problems do occur in a duplex system it is necessary to identify as many abnormal conditions as possible to zero in on the specific cause of the problem. Unfortunately, there are only a few measurable or observable performance indicators at the disposal of the field serviceman, and any number of conditions may exist, even simultaneously, which are responsible for the observed phenomena. Most Duplexer installation problems fall into three categories. Each of these three conditions will be treated separately, using the typical cause and remedy approach.

- A. High input VSWR**
- B. Excessive loss**
- C. Desensitization of the receiver when transmitter is keyed**

PROBLEM			POTENTIAL CAUSE	
A	B	C	THE NUMBER AT RIGHT CORRESPONDS TO THE APPROPRIATE NUMBERED REMEDY PARAGRAPH	
●	●		Reverse labeling of Tx and Rx terminals.	1
●	●		Unit tuned to wrong frequencies.	2
●			Bad antenna or interconnect cables.	3
●	●		Use of between series adapters, especially UHF types.	4
●	●	●	Duplexer detuned in shipment.	5
●	●		Water has entered the Duplexer antenna connector from the antenna feed line.	6
●	●		Spurious Tx output is being reflected by the selective Duplexer input terminal and observed on the wattmeter, the wattmeter being unable to discriminate between on-frequency and off-frequency energy.	7
		●	Bad joint in a cable or antenna system beyond the antenna terminal of the Duplexer. All lines may show zero reflected power, but noise can still be produced when a corroded or indefinite metal-to-metal contact is exposed to RF energy. When this occurs beyond the Duplexer, it cannot be filtered out, and the noise backs up into the receiver	8
		●	Adverse cable length between Duplexer and transmitter using varactor or broadband hybrid combining type transmitter outputs. Even though the Duplexer VSWR is flat on frequency, the reflected impedance of the Duplexer off resonance, transformed by changing cable lengths, can cause parasitics to be generated.	9
		●	Duplexer transmitter mixing with another outside transmitter, producing intermodulation on or near the receiver frequency.	10
		●	Transmitter cable leading to Duplexer in close proximity to Duplexer antenna or receiver cable. This is usually only a problem on close separation Duplexers, (1.0 MHz or less) where the 85 to 100 dB isolation is decreased by adverse coupling, created by running these cables too close together for too great a distance.	11
		●	Inadequate shielding of transmitter and receiver modules in the repeater.	12
		●	Insufficient duplex isolation for the application.	13
		●	A spurious transmitter response outside of the normal Duplexer isolation band or inadequacy of notch filter type Duplexers to suppress a wide enough band of Tx noise to protect the receiver.	14
		●	Impedance change in antenna due to icing. VSWR increase may be sufficient to reflect back through the Duplexer and upset transmitter tuning, causing parasitics, which are not suppressed sufficiently by the Duplexer.	15
		●	The addition of a broadband power amplifier to a low power transmitter. The noise floor of the low power radio is raised by an amount equal to the gain of the power amplifier, and in addition, the power amplifier will contribute its own noise. Power amplifiers are just as prone to the generation of parasitics as transmitters, and may be triggered by an adverse cable length between power amplifier and Duplexer, a problem covered above.	16
		●	Excessive loss with changing temperature and apparent Duplexer detuning.	17

## REMEDIES

1. Tune a signal generator to the receive frequency and inject it into the antenna terminal, sampling for the signal at each equipment terminal. Reverse the labels if necessary. It may be that the unit was ordered to the reverse frequencies. If so, the label will indicate this. If the duplexer is symmetrical in design (usually indicated by the same number of Tx and Rx filter sections) just reverse the equipment labels and operate. Generally, no damage will be done to the duplexer when operated in reverse for a short time period. If other adverse symptoms appear, contact the factory.

2. Check the unit label. If needed, the duplexer may be field tuned. Consult the instructions and/or the factory if the duplexer is still under warranty or beyond field tuning capability.
3. Check cable, by substitution, using a terminal wattmeter, or a thru-line wattmeter into a known good load. Check the antenna line input for reflected power.
4. To eliminate high input VSWR reduce the number of between series adapters by making up proper interconnect cables. UHF connectors are non-constant impedance, and certain combinations can transform a 1.1:1 VSWR into a 2.0:1, or vice versa.
5. Consult the instruction manual for field tuning procedures, or the factory, if the unit is still under warranty or beyond field tuning capability. (We trust that our products will not be prone to this problem).
6. Consult the factory. The affected antenna cables may be field replaceable, or a "baking out" process may be possible.
7. To prove this condition, place a bandpass filter between the Tx and duplexer to clean up the spurious, and put the wattmeter between the bandpass filter and the duplexer to measure reflected power from the duplexer. The bandpass filter selectivity should be equal to or better than that of the duplexer at about the 3.0 dB points.
8. Operate the duplex system into a dummy load. If no desensitization occurs, check out all lines, antennas, and look for potential bad joints close to the radiating antenna where re-radiation of noise may be possible back into the antenna system receiver. Loose metal-to-metal contacts on tower guying systems have also been known to create system noise. Note the effect of vibrating tower guys on system noise.
9. Change the length of cable between the transmitter and duplexer, traversing through a half wave in increments of between 1 and 2 inches until the desensitization ceases or is minimal. A ferrite isolator will also cure this condition when it is installed between the transmitter and duplexer. However, this is a much more expensive remedy.
10. If the IM is in the duplex transmitter, a ferrite isolator in the duplex transmitter line (NOT antenna line) will show this by either reducing or eliminating it. More isolation can be obtained by cascading isolators if needed. However, IM of this magnitude indicates the system should be studied for possible revision to reduce the production of this IM.
11. Cables such as RG-8a/u and RG-213/u should be kept at least 3-4" apart over 5'-10' runs. Use of double shielded cable will reduce the susceptibility to this problem.
12. Consult the radio manufacturer. This condition can be verified by operating the transmitter into a dummy load while injecting a minimum quieting signal into the receiver. Some radios require special modifications before they are suitable for repeater operation.
13. If this problem is suspected, contact the radio manufacturer for recommended duplex isolation for Tx noise suppression and carrier suppression. Duplexer isolation should be measured first per instruction manual to verify rated specifications are present. If more duplex isolation is required, contact TX RX SYSTEMS for recommended filtering.
14. Consult the factory. Bandpass filter tests can be made to confirm this. In extreme cases, adjustments to the transmitter may be required.
15. Either de-ice the antenna, or use an antenna less sensitive to ice. A ferrite isolator can also be put at the transmitter output to improve the impedance match. Ferrite isolators cannot be put in antenna lines, as they will attenuate Rx signals.
16. A mismatch may possibly be reduced by lengthening the cable which runs between the power amplifier output and the duplexer input until the receiver desensitization disappears, as follows  
**30 MHz to 512 MHz RANGE;** BNC or N type adapters may be inserted in the original cable, one at a time and not to exceed a total of 1/2 wavelength, until desensitization disappears.  
**800 MHz to 1.3 GHz RANGE;** Prepare a cable length 3/4" longer than the original cable and insert. If desensitization does not disappear, repeat with cables each 3/4" longer than the previous length, not to exceed 1/2 wavelength.
17. We find that this cause most commonly relates to shifting impedance of the transmitter or power amplifier with temperature. The duplexer appears detuned, since a "conjugate match" (canceling reactance, and matching resistance component) is approached by shifting the duplexer passband above or below the 50 ohm point, as determined by an increase in output power on the wattmeter. In this case, temperature control of the room is the only answer, other than upgrading the transmitter.

# POWER IN/OUT VS. INSERTION LOSS

The graph below offers a convenient means of determining the insertion loss of filters, duplexers, multicouplers and related products. The graph on the back page will allow you to quickly determine VSWR. It should be remembered that the field accuracy of wattmeter readings is subject to considerable variance due to RF connector VSWR and basic wattmeter accuracy, particularly at low end scale readings. However, allowing for these variances, these graphs should prove to be a useful reference.

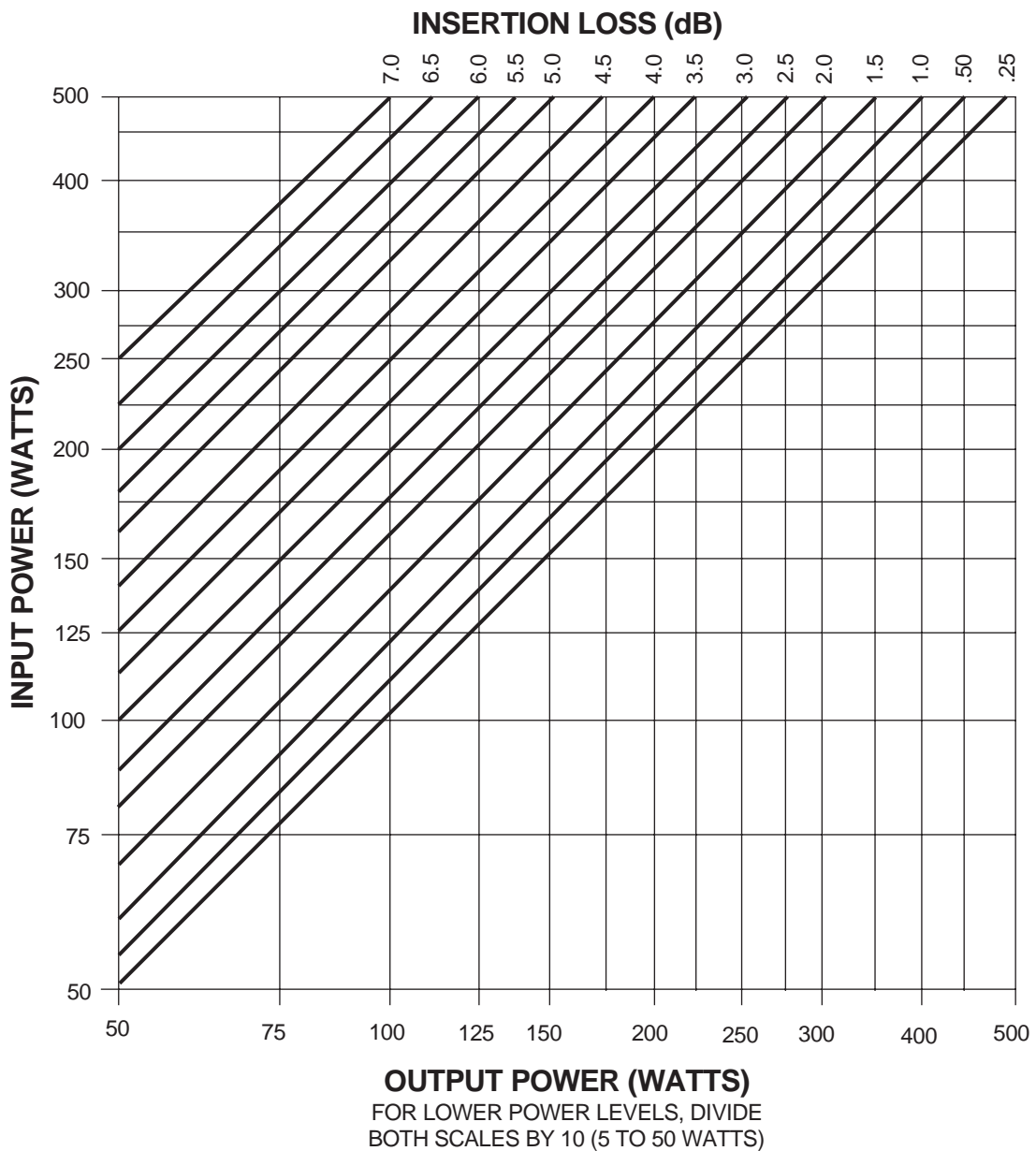

# POWER FWD./REV. VS. VSWR

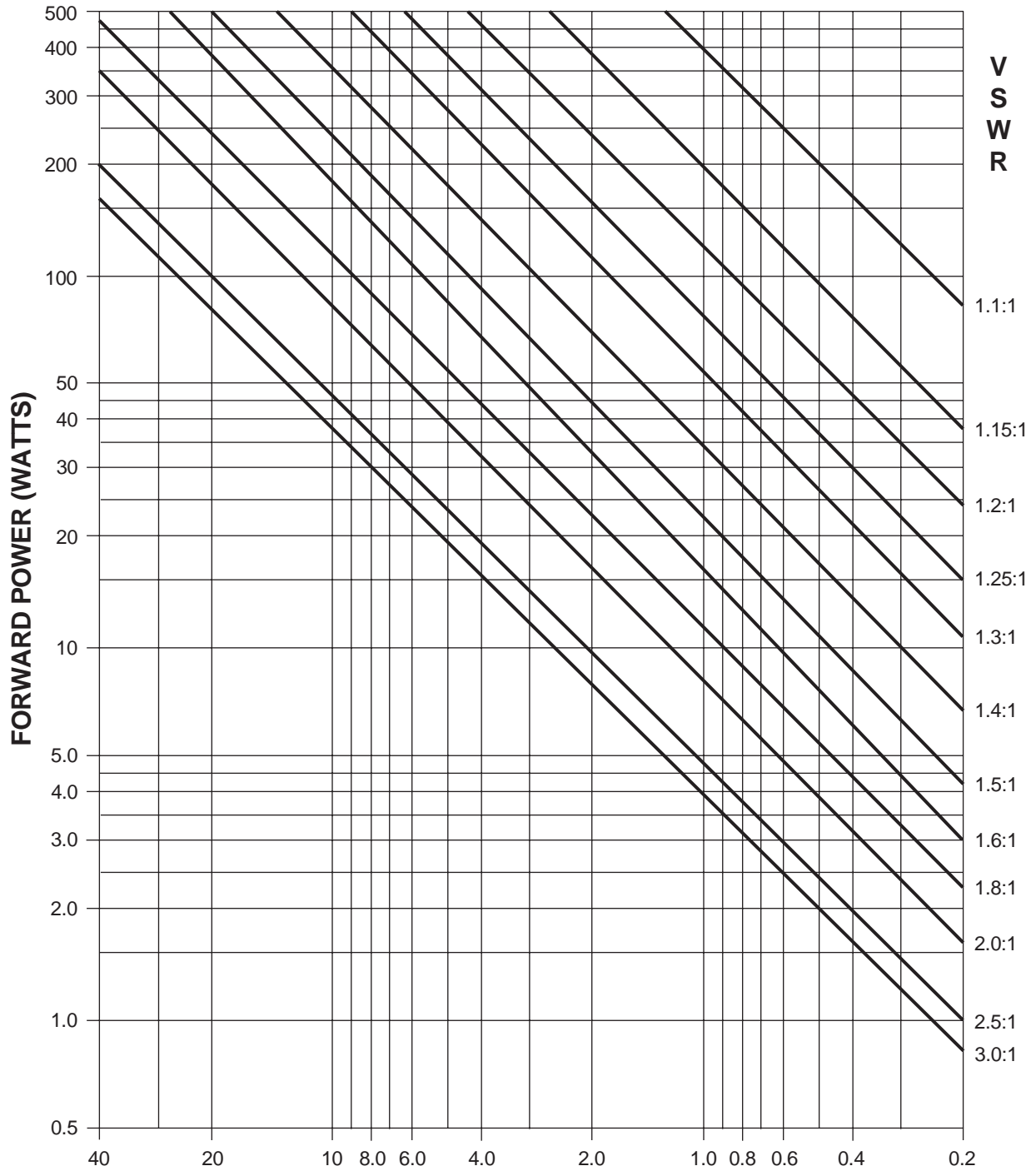

## REFLECTED POWER (WATTS)

FOR OTHER POWER LEVELS, MULTIPLY  
BOTH SCALES BY THE SAME MULTIPLIER