

TUNING INSTRUCTIONS
SINCLAIR MODELS:

Q-202G Q-208G, Q-218G
Q-2B01G, Q-2B02G, Q-2B17G

Manual CM-112

SINCLAIR RADIO LABORATORIES INC.

PO BOX 23
TONAWANDA, NY

675 ENSMINGER ROAD
14150

DUPLEXER INSTALLATION PROCEDURE

CI-056

This duplexer comes to you tuned and ready to install in the system, no field tuning has to be done on the duplexer. The following steps should be followed to insure proper installation.

1. Verify that your station duplex frequencies are the same as those to which the duplexer is tuned. These frequencies are on the unit identification label.
2. Without the duplexer in the system, tune the transmitter into the station antenna and measure the output and reflected power. These readings will be used as the parameters to which the duplexer is compared.
3. Install the duplexer into the system with the wattmeter between the transmitter and duplexer. Connect the station antenna to the duplexer antenna terminal. Return the transmitter and read the forward and reflected power. From the chart on the back of this page, using these power readings, the VSWR of the duplexer can be found. The typical VSWR is 1.25:1 or less, the maximum is 1.5:1.
4. Next, measure the output power from the duplexer into the station antenna. Divide this reading by the net input power (net input power = input power - reflected power from #3). Go to page DS-1001 at the end of this manual and look down the heading Power Ratio, for a number that is closest to the calculated value. Then look to the right of this number, under the DB Column, and read the insertion loss of the duplexer. This value should be equal to, or less than, the specification of the duplexer.
5. To check the receiver insertion loss, inject the receiver frequency into the receiver with a signal generator and obtain an unsaturated first limiter reading, note the generator output level. Next connect the receiver terminal of the duplexer to the receiver and inject the receiver frequency into the antenna terminal of the duplexer. Adjust the generator for the same limiter reading and note the generator output level. The difference between this reading and first reading is the insertion loss of the duplexer.

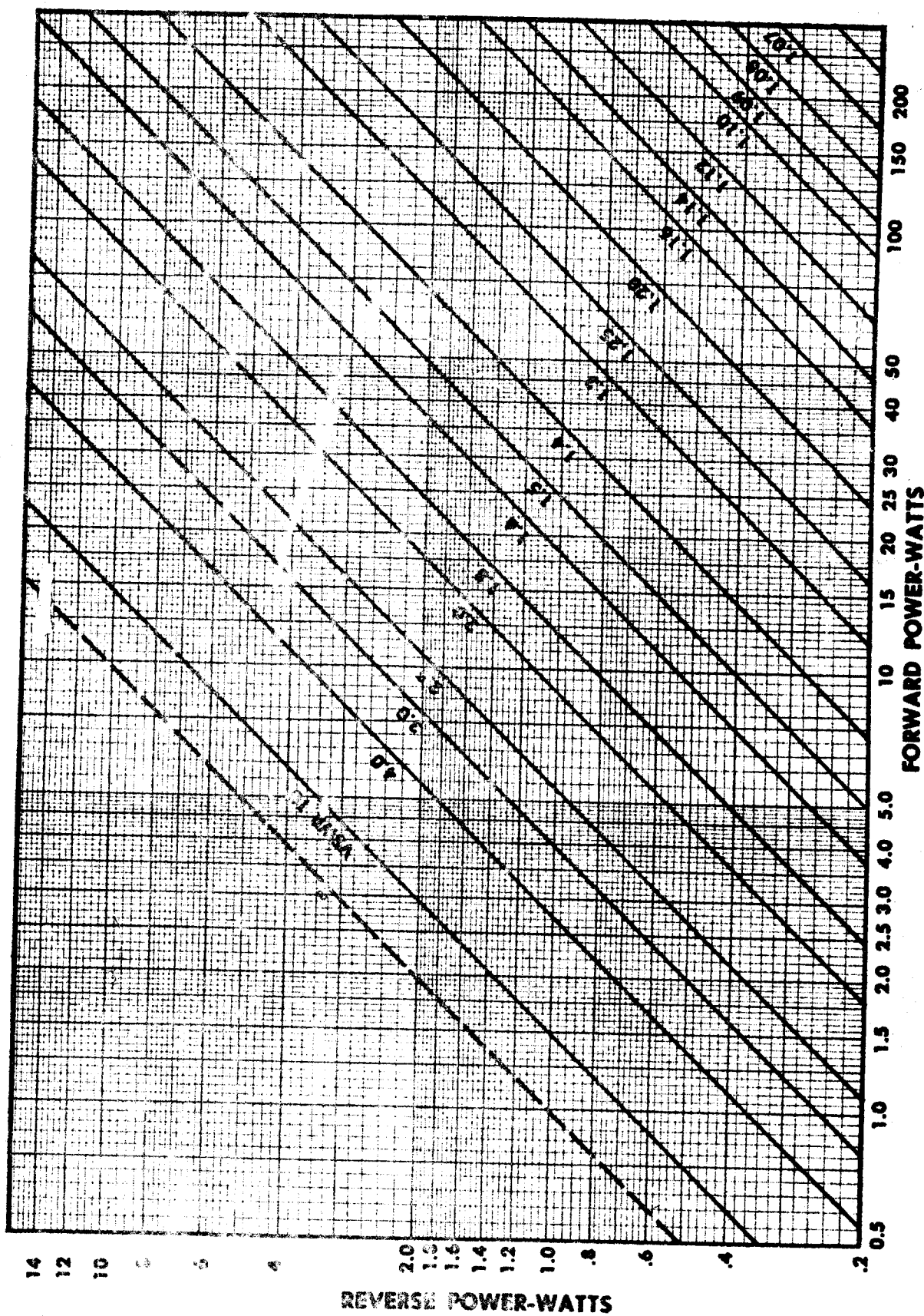

POWER VALUES vs. VSWR

TUNING INSTRUCTIONS

Models: Q-202G, Q-208G, Q-2B01G, Q-2B02B
Q-218G, Q-2B17G

IN GENERAL:

The duplexers can be retuned to a minimum of 500 KHz separation in their respective bands (Q-202G and Q-208G, 148-174 MHz; Q-2B01G and Q-2B02G, 132-148 MHz). Both bands are split in half for purposes of optimizing standoff cables, L2, see ID-3099. Therefore if the duplexer you are retuning has to be shifted out of its originally ordered frequency sub-band (as stated above) you will have to change L2 cables to realize optimum specifications.

When retuning a duplexer to frequencies very close to the originals (appx. ± 1 MHz of mean frequency) follow steps ① through ⑥ to complete tuning. When a greater shift is needed then follow steps ① through ⑥ then repeat ③ ④ ⑤ ⑥ in this order.

EQUIPMENT:

Minimum equipment requirements for tuning are: FM Signal Generator (measurements model 560M or equivalent), receivers on each of the two duplex frequencies (or one which will tune both) and a first limiter monitor meter. See CI-096 for basic test circuit. Sheets ID-3099 and ID-3019 give circuit diagram and individual cavity detail respectively.

PROCEDURE:

As you follow below steps be certain to adjust the output of the signal generator as necessary to maintain a readable but unsaturated level on the first limiter monitor.

- ① Inject high duplex frequency into H.F.T. (high frequency terminal) and detect it at antenna terminal. (monitor 1st limiter of receiver on that frequency) Adjust the cavity tuning rod of C1 and of C2 for maximum signal to receiver.
- ② Inject low duplex frequency into L.F.T. (low frequency terminal) and detect it at antenna terminal. Adjust the cavity tuning rod of C3 and of C4 for maximum signal to receiver.
- ③ Inject low duplex frequency into H.F.T. and detect it at L.F.T., adjust the dielectric stubs on cavities C1 and C2 for minimum signal to receiver. Lock stubs in position.
- ④ Inject high duplex frequency into L.F.T. and detect it at H.F.T., adjust the dielectric stubs on cavities C3 and C4 for minimum signal to receiver. Lock stubs in position.
- ⑤ Repeat step ① then lock tuning rods in position.
- ⑥ Repeat step ② then lock tuning rods in position.

● INDICATES TEE CONNECTOR
UG 28 a/u OR UG107 b/u

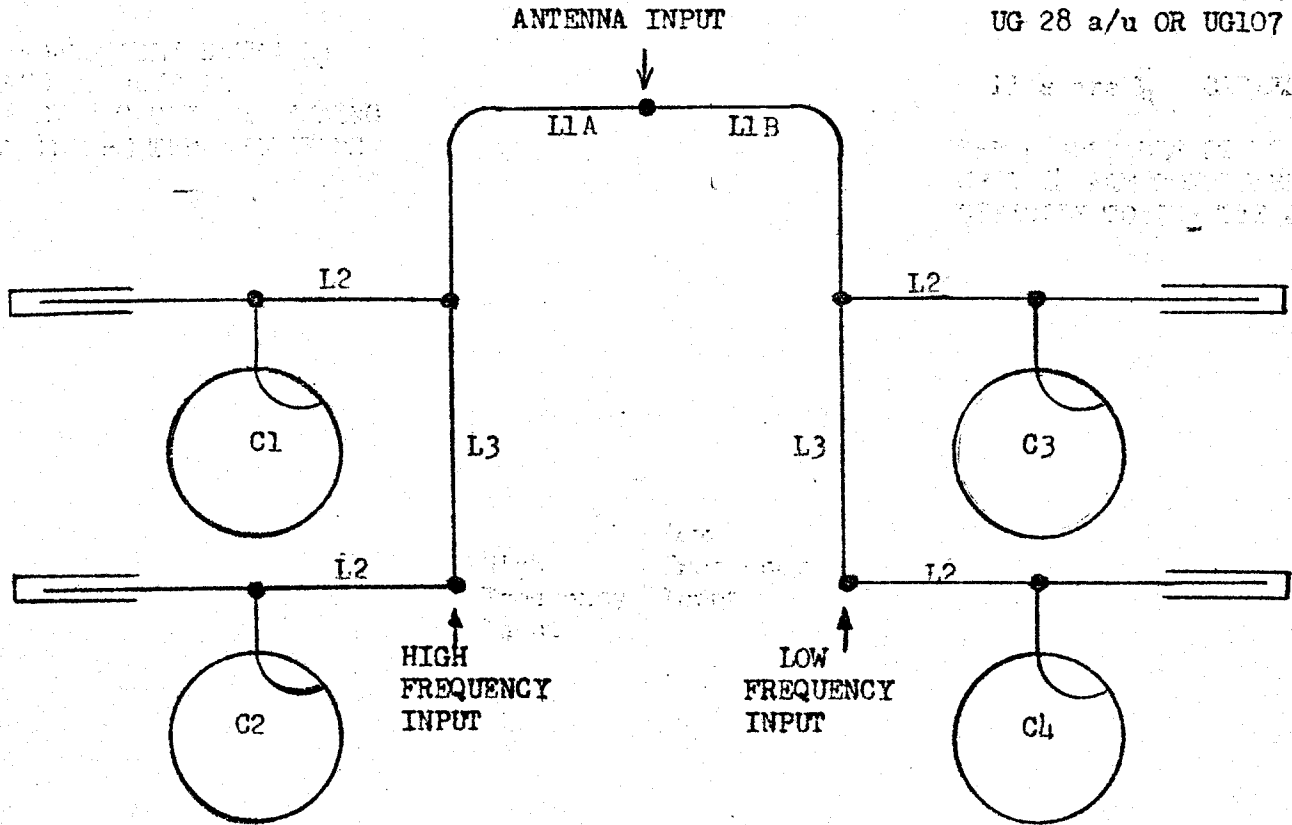

L2 CABLE LENGTHS:

Q-202G: 148-161 = 10.5" / 161-174 = 9.5" Q-208G: 148-161 = 11.1" / 161-174 = 10.1"
Q-2B01G: 132-140 = 12.0" / 140-148 = 11.0" Q-2B02G: 132-140 = 12.7" / 140-148 = 11.6"

SEE ID-3019 FOR INDIVIDUAL FILTER SECTION DESCRIPTION
AND TUNING PROCEDURE

C1 and C2 ARE TUNED TO REJECT THE LOW FREQUENCY AND PASS THE HIGH FREQUENCY
TYPICAL VALUES ARE: 35 db REJECT .6 db INSERTION LOSS

C3 and C4 ARE TUNED TO REJECT THE HIGH FREQUENCY AND PASS THE LOW FREQUENCY
TYPICAL VALUES ARE: 35 db REJECT .6 db INSERTION LOSS

TYPICAL SPECIFICATIONS FOR THIS UNIT ARE:
INSERTION LOSS TX 1.5 db Rx 1.5 db

ISOLATION TX NOISE AT RX FREQUENCY 80 db
TX FREQUENCY AT RX TERMINAL 80 db

MINIMUM ISOLATION BETWEEN TX AND RX FREQUENCIES: 50 db

MINIMUM SEPARATION 500 KHz

INTERCABLING DIAGRAM

No. 3099 PAGE 1 OF 1 DATE 4/71

MODEL Q-202G Q-208G

ASSEMBLY No. _____

QUOTE No. _____

REL. PERFORMANCE CURVES _____

RELATED CABLE _____

DESIGN SHEET C. S. No. _____

SINCLAIR RADIO LABORATORIES, INC.
P. O. BOX 23 TONAWANDA, NEW YORK 14150

WIRING DIAGRAM NOTATION

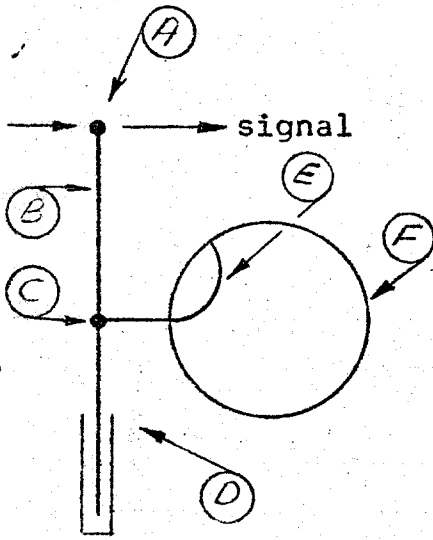

TOP MOUNTED LOOP

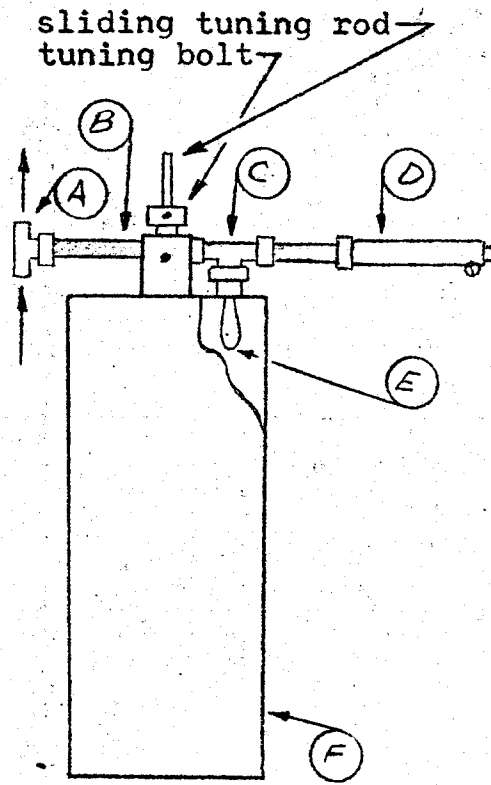

Q - SWITCH BOX

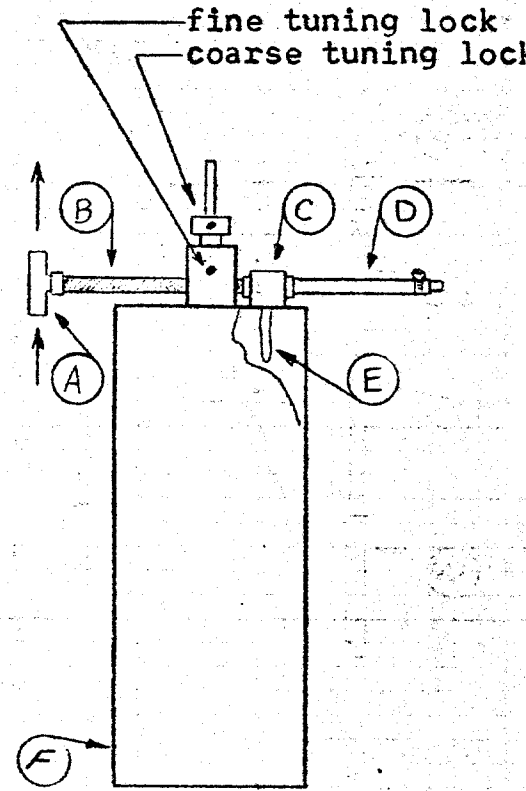

- (A) Is the tee connector across which the filter section response occurs
- (B) Is the $\frac{1}{4} \lambda_g$ (appx.) stand off cable
- (C) The tee connector across the cavity input or Q-switch box
- (D) Is the adjustable open stub section (see DS No. 1025 for adjustable open stub description.) The stub may be attached directly to tee (C) or there may be some length of cable connecting it to tee (C)
- (E) Is the loop which couples into the cavity. The size and position of loop determine the insertion loss of the filter section, in general the larger the loop the smaller the insertion loss.
- (F) Is the cavity body.

NOTE: Q SERIES FILTER SECTIONS PATENT PENDING

INTERCABLING DIAGRAM

No. ID-3019 PAGE 1 OF 2 DATE Jan. 68

MODEL 6" Dia. Q-Switch Filter Sections

ASSEMBLY No. _____

QUOTE No. _____

RELATED PERFORMANCE CURVES PC-093, 094, 095, 096

RELATED CABLE

DESIGN SHEET C. S. No. _____

SINCLAIR RADIO LABORATORIES, INC.

P. O. BOX 23 TONAWANDA, NEW YORK 14150

GENERAL THEORY

The filter section response appears across tee connector (A). A notch or rejection null is created at the unwanted frequency with the variable open circuited stub. The cavity probe is adjusted for minimum insertion loss at the desired pass frequency. (It will be noted that this filter operates in a reverse manner as compared with a conventional notch filter where the cavity probe tunes the rejection notch).

PROCEDURE FOR RETUNING Q-SWITCH FILTER SECTIONS TO ORIGINAL DESIGN FREQUENCIES

1. Feed the frequency to be passed across tee (A) and tune cavity probe for minimum insertion loss, the position of stub ST-1 has no effect on this step.
2. Feed the frequency to be rejected across tee (A) and tune the adjustable stub for a maximum attenuation of this signal.
3. Repeat steps 1 and 2 once as a final check. The stub is always set last. The stub has no appreciable effect on the setting of the cavity probe for the pass frequency, but the setting of the cavity probe will affect the required setting of the rejected frequency. It is for this reason that the stub is set last. Lock cavity probe and stub in place.

For retuning cavities to frequencies other than original design frequencies consult factory for detailed tuning instructions.

For measurement techniques see FIELD FILTER TEST CIRCUIT, CI-096.

INTERCABLING DIAGRAM

No. ID-3019 PAGE 2 OF 2 DATE Jan. '6

MODEL 6" Dia. Q-Switch
Filter Sections

ASSEMBLY No. _____

QUOTE No. _____

RELATED PERFORMANCE CURVES

PC-093, 094, 095, 096

RELATED CABLE

DESIGN SHEET C. S. No. _____

SINCLAIR RADIO LABORATORIES, INC.

P. O. BOX 23 TONAWANDA, NEW YORK 14150

INFORMATION SHEET
Q-SWITCH OPEN CIRCUITED STUB

D.S. No. 1025
Page 1 of 1
October 1971

The following discussion applies to all Q-Switch Filters which have the stub, coupling loop and standoff cable built into one integrated assembly.

The stub is an open circuited section of coaxial transmission line, whose electrical length can be varied through two adjustments. A vernier adjustment is accomplished by sliding the dielectric tuning rod over the center conductor. A fixed change in the center conductor length is accomplished by changing center sections.

Depending on the particular Q-Switch Filter, the lengths and number of removable center sections vary. The removable center conductor lengths are chosen so that a continuous electrical length adjustment can be achieved with a slight overlap. Inserting the dielectric electrically lengthens the stub and withdrawing the dielectric shortens the stub. For example: When tuning the reject notch of the filter, if the dielectric pushes all the way in as a null is approached, but not peaked, the stub center section wants to be longer. Remove the existing section and screw on the next longer one. Conversely, if the dielectric pulls out all the way, as a null is approached, but not peaked, remove the existing section and install the next shorter one. (The one inch section can be screwed on from either end thus, giving the smallest length possible for the stub). Stub center conductor sections for each filter are available free of charge if they are required for retuning.

When adjusting the stub in any filter circuit, the fixed center conductor section should be used where a minimum of 1/8" or dielectric rod covers and end of the center conductor at final setting. This is to ensure mechanical stability.

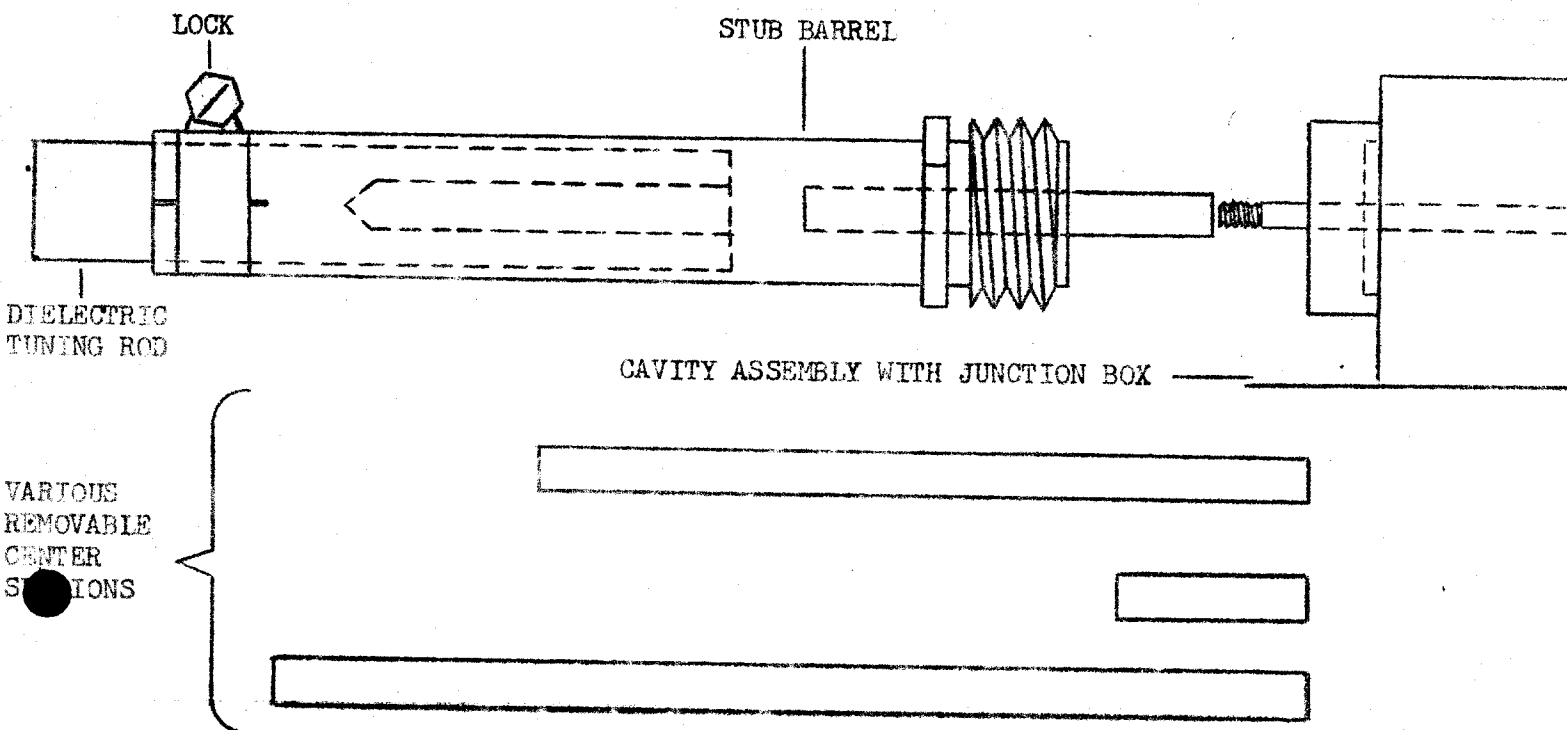

ATTENUATION AND INSERTION LOSS FIELD MEASUREMENT TECHNIQUES

CI-096-1/3

These instructions are intended to provide reasonably accurate insertion loss and attenuation measurements on filters, duplexers and multicouplers in the field using minimum test equipment.

INSERTION LOSS MEASUREMENTS

Two methods are presented, the first is used for measuring transmitter insertion loss using the transmitter and a wattmeter. The second method is general and can be used for either transmitter or receiver insertion loss measurements.

TRANSMITTER INSERTION LOSS MEASUREMENTS - The VSWR of the wattmeter should be 1.2:1 or less and the use of numerous adaptors in making connections should be avoided because the VSWR of these is often poor and will degrade the measuring system. UHF adaptors and connectors should be avoided when ever possible because their impedance characteristics vary widely with frequency.

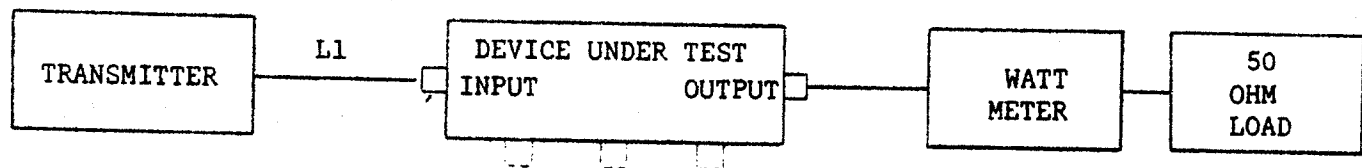

Install the device to be measured in the circuit as shown above, tune the transmitter for maximum power out. If the reflected power is not zero or near zero, then cable L1 should be adjusted to give the highest output power (lowest reflected power) when tuning the transmitter into the device. There will be some VSWR looking into the device and length L1 will determine the reactive component reflected to the transmitter. Because the adjustment range of the transmitter output is limited, it has been found that adjustment of L1 for maximum output can prove advantageous for lowest insertion loss.

An arbitrary length for L1 may be chosen and then varied by the addition of 1/8, 1/4, or 3/8 wavelengths, each time retuning the transmitter. The addition of one of these lengths, or the initial length of L1 will give maximum power out with a minimum of plate current. The trial lengths for polyethylene dielectric (solid) cables can be computed from these formulas.

$$\lambda g/8 = 973/\text{freq. in MHz}, \quad \lambda g/4 = 1946/\text{freq. in MHz}, \quad 3\lambda g/8 = 2919/\text{freq. in MHz}$$

When maximum power output has been obtained through the device, note this power, then disconnect the device from the final length of L1 and connect directly to the wattmeter and load. Retune the transmitter, maintaining the same coupling and note the power output. You can now compute the power ratio, which is equal to power out (with device)/power out (without device). Page CI-099 will give the insertion loss value for the calculated power ratio.

SUBSTITUTION METHOD FOR INSERTION LOSS MEASUREMENT - Assemble the test set up as shown on the next page. The remaining terminals need not be terminated if the device under test is a duplexer or multicoupler. Inject the frequency and obtain a reference level on the first limiter monitor, taking care not to saturate the limiter circuit. Note the microvolt signal level and the generator output (dbm). Next, inject the signal directly into the receiver and decrease the signal generator output until the same reference level is obtained. The insertion loss is the difference in dbm as taken from the generator dial or the ratio of microvolts, using the following relationship,

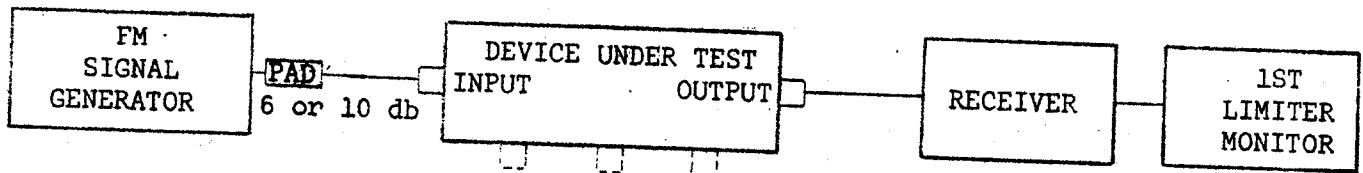

and then referring to the table on CI-099.

$$\text{Voltage ratio} = \frac{\text{microvolts (w/o device)}}{\text{microvolts (w/device)}}$$

A step attenuator providing small db increments (0.1, 0.2, 0.5, 1.0) can be used to provide more accurate readings. The attenuator should be connected to the generator output. Snap in and leave in about 6 db to pad the generator output. Take the reading with the device in the circuit, then remove the device and connect the two leads together. Snap in attenuation to bring the level down to the same reference level. The insertion loss is the equal to the amount of dbs snapped in (do not count in the value you had for padding purposes).

EQUIPMENT NOTES:

1. Quick slip connectors can be made by sawing off the outer barrel of male plugs. They can then be inserted in a variety of female contacts such as "N", "BNC", or "TNC" jack.
2. Use a minimum of adaptors in test cables, especially UHF and conversion types between "N", "UHF", or "BNC". The VSWR and associated phase shift of "UHF" type connectors can cause erroneous readings, especially when measuring low values of insertion loss.
3. FM signal generator may be measurements model 560 M or equivalent. The step attenuator is one providing 0.1 db increments for measurement of low insertion losses using the substitution method. This may be omitted and the attenuator on the signal generator substituted, but with substantial loss of resolution. (Kay model 1/432 C or equivalent).
4. The length between the duplexer and the receiver may have some effect on insertion loss and may be adjusted if desired, but it has been found that the receiver is not as sensitive or as easily disturbed by slight mismatches.

ATTENUATION MEASUREMENTS

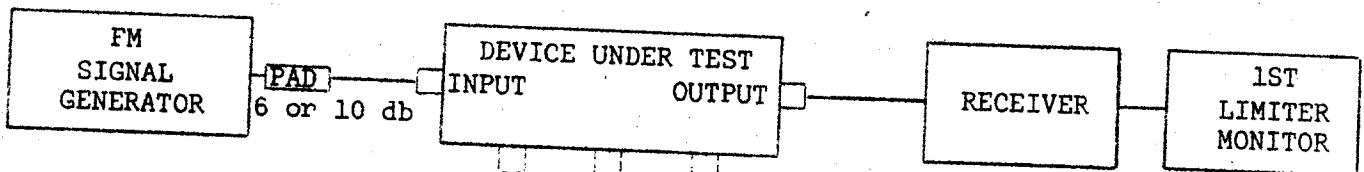

Insert the two terminals, between which the attenuation is to be measured, into the test circuit above. If the device has more than two terminals, as a duplexer or multicoupler, terminate all remaining terminals with 50 ohms before making measurements.

Using a signal generator and receiver on the test frequency, set the signal generator drive for a readable but unsaturated level on the list limiter monitor. Note a reference level on the first limiter monitor and the dbm level on the signal generator attenuator or the microvolt reading on the generator attenuator. Remove the filter termin-

SINCLAIR RADIO LABORATORIES INC.

CI-096-3/3

als and connect leads of the test circuit together. Reduce the output on the signal generator until the reference level on the 1st limiter monitor is obtained. Note the dbm level on the signal generator attenuator. The difference between this and the previous level represents the filter attenuation in db. If the microvolt readings are used, the attenuation can be obtained from the ratio of the two readings, then referring to the chart on CI-099 using the closest tabulated value.

Voltage ratio = microvolts (w/o device)/microvolts (w/device)

Consult the data Sheet or Detailed Tuning Procedure of the particular model under test for typical values of Insertion loss and attenuation.

PRECAUTIONARY MEASURES FOR MORE RELIABLE MEASUREMENTS - RF leakage is occasionally a problem when measuring filter attenuations in the area of 60 db or greater. When measuring attenuations over 80 db, RG-58/u cable should not be used because of excessive radiation. RG-8A/u or RG-213/u cable will permit measurements of 100-110 db only if input and output filter cables are not in close proximity. Double shielded cable, as RG-9/u or RG-142/u, is advised for measurements over 80 db. Occasionally, RF leakage occurs because of excessive radiation from the signal source, insufficient shielding of the receiver or a combination of all the above. If the measurements of a filter section indicates a lower level of attenuation than expected, a parallel path of lower attenuation (RF leakage) may be the reason. If this occurs, you will not be able to measure attenuations greater than the leakage path. If leakage is suspected, a simple test can be made as follows: insert the terminals of the filter under test and obtain a reference level on the first limiter monitor, using sufficient generator drive for a readable but unsaturated level. Note the dbm level of drive on the signal generator. Now insert a known level of attenuation in series with the filter section, as a 6 or 10 db pad. It should be necessary to increase the signal generator drive, in dbm, by the amount of attenuation added to obtain the previous reference level on the first limiter monitor. If RF leakage is occurring, the signal generator drive will be practically the same, indicating a path for RF other than thru the filter section. It can be easily shown if the filter section is responsible for the RF leakage. The results of the leakage test should be unaffected by placing the additional attenuation before or after the filter section in the test circuit, allowing for slight variation due to possible VSWR level of the attenuator. The 10 db pad should be left on the generator output at all times since the generator is looking into an unmatched line at this frequency. In actual practice, the cable length connecting the transmitter to the duplexer will affect the total amount of noise suppression, since the transmitter is an unmatched source of receiver noise power on the receiver frequency and is looking into a reflective load. The cable length which gives the greatest mismatch at the receiver frequency will provide the best noise suppression. Likewise, an adverse length can be chosen which will actually reduce the noise suppression by about 6 db less than the value measured, using a padded signal source. Unfortunately, this length is already adjusted for the best transmitter output through the duplexer. Since there are a few other uncontrollable factors affecting noise suppression such as varying frequency separations and internal extension cable lengths in the duplexer, the best solution is to provide an adequate safety margin of 10-15 db above the theoretical value specified by the manufacturer or systems supplier.

SINCLAIR RADIO LABORATORIES INC.

CONVERSION OF VOLTAGE AND POWER RATIOS TO DECIBELS

CI-099

VOLTAGE RATIO	POWER RATIO	DB	VOLTAGE RATIO	POWER RATIO	ATTENUATION DB
1.0000	1.0000	0.0			
.9886	.9772	0.1	.5012	.2512	6
.9772	.9550	0.2			
.9661	.9333	0.3	.3162	1 x 10 ⁻¹	10
.9550	.9120	0.4			
.9441	.8913	0.5	.1778	.3162 x 10 ⁻¹	15
.9333	.8710	0.6			
.9226	.8511	0.7	1 x 10 ⁻¹	1 x 10 ⁻²	20
.9120	.8318	0.8			
.9016	.8128	0.9	.5623 x 10 ⁻¹	.3162 x 10 ⁻²	25
.8913	.7943	1.0			
.8810	.7762	1.1	.3162 x 10 ⁻¹	1 x 10 ⁻³	30
.8710	.7586	1.2			
.8610	.7413	1.3	.1778 x 10 ⁻¹	.3162 x 10 ⁻³	35
.8511	.7244	1.4			
.8414	.7079	1.5	1 x 10 ⁻²	1 x 10 ⁻⁴	40
.8318	.6918	1.6			
.8222	.6761	1.7	.5623 x 10 ⁻²	.3162 x 10 ⁻⁴	45
.8120	.6607	1.8			
.8035	.6457	1.9	.3162 x 10 ⁻²	1 x 10 ⁻⁵	50
	.6310	2.0			
.7852	.6166	2.1	.1778 x 10 ⁻²	.3162 x 10 ⁻⁵	55
.7762	.6026	2.2			
.7674	.5888	2.3	1 x 10 ⁻³	1 x 10 ⁻⁶	60
.7586	.5754	2.4			
.7499	.5623	2.5	.5623 x 10 ⁻³	.3162 x 10 ⁻⁶	65
.7413	.5495	2.6			
.7328	.5370	2.7	.3162 x 10 ⁻³	1 x 10 ⁻⁷	70
.7244	.5248	2.8			
.7161	.5129	2.9	.1778 x 10 ⁻³	.3162 x 10 ⁻⁷	75
.7079	.5012	3.0			
.6999	.4898	3.1	1 x 10 ⁻⁴	1 x 10 ⁻⁸	80
.6918	.4786	3.2			
.6839	.4677	3.3	.5623 x 10 ⁻⁴	.3162 x 10 ⁻⁸	85
.6761	.4571	3.4			
.6683	.4467	3.5	.3162 x 10 ⁻⁴	1 x 10 ⁻⁹	90
.6607	.4365	3.6			
.6531	.4266	3.7	.1778 x 10 ⁻⁴	.3162 x 10 ⁻⁹	95
.6457	.4169	3.8			
.6383	.4074	3.9	1 x 10 ⁻⁵	1 x 10 ⁻¹⁰	100
.6310	.3981	4.0			
.6237	.3890	4.1	.5623 x 10 ⁻⁵	.3162 x 10 ⁻¹⁰	105
.6166	.3802	4.2			
.6095	.3715	4.3	.3162 x 10 ⁻⁵	1 x 10 ⁻¹¹	110
.6026	.3631	4.4			
.5957	.3548	4.5	.1778 x 10 ⁻⁵	.3162 x 10 ⁻¹¹	115
.5888	.3467	4.6			
.5821	.3388	4.7	1 x 10 ⁻⁶	1 x 10 ⁻¹²	120
.5754	.3311	4.8			
.5689	.3236	4.9			
.5623	.3162	5.0			

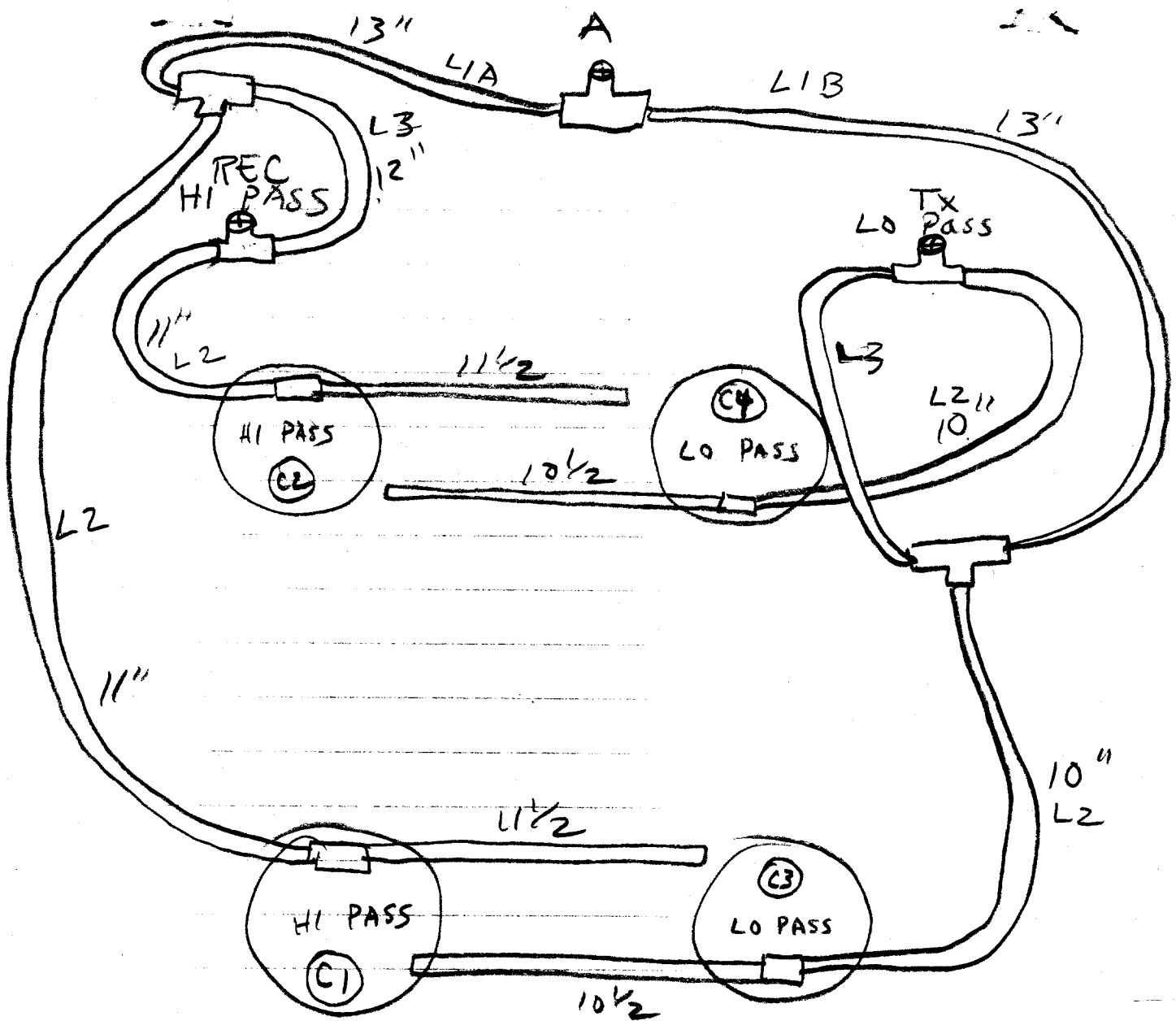

Q 202 G

T-166.725

R-168.125